

Flat Steel System



Erection Anchor

Designed to edge lift panel to vertical position with use of shear bar or shear plate.

See page 39 for shear bar information.

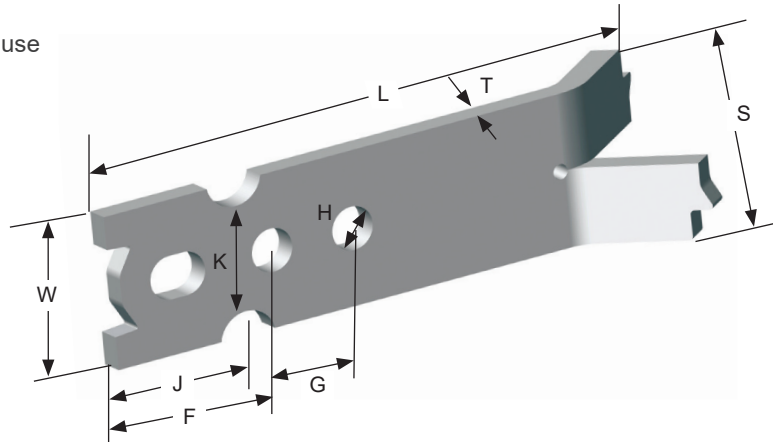
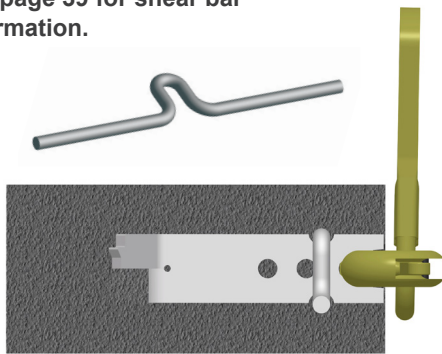

TON	SYS CODE	ITEM CODE	BODY LENGTH (L)	BODY WIDTH (W)	BODY THICK. (T)	NOTCH LOCATION (J)	NECK WIDTH (K)	HOLE DIA. (H)	HOLE CENTERS (G)	HOLE LOCATION (F)	SPREAD (S)
2	2.5	FEA02080	8"	2"	3/8"	1-13/16"	1-3/8"	9/16"	1-1/8"	2-1/4"	2-3/4"
4	5	FEA04105	10-1/2"	2-1/2"	5/8"	2-1/2"	1-13/16"	3/4"	1-1/4"	3-3/16"	3-3/8"
8	10	FEA08128	12-13/16"	3-3/4"	3/4"	3-1/8"	2-7/16"	1"	1-3/4"	4"	5"
10	10	FEA08128-10T	12-13/16"	3-3/4"	3/4"	3-1/8"	2-7/16"	1"	1-3/4"	4"	5"

TON	SYSTEM CODE	ITEM CODE	PANEL THICKNESS	SWL SHEAR W/SHEAR BAR (LBS)	SWL TENSION W/O TENSION BAR (LBS)	SWL TENSION W/TENSION BAR (LBS)
2-Ton Ring Clutch (2 Ton Anchor)						
2	2.5T	FEA02080	4"	1950	3190	4000
			5"	2105	3885	
			6"	2535	4000	
			7"	2885	4000	
			8"	3145	4000	
			9"	3445	4000	
			10"	3625	4000	
			11"	3885	4000	
4-Ton Ring Clutch (4 Ton Anchor)						
4	5T	FEA04105	6"	3000	5185	8000
			7"	3155	6015	
			8"	3445	6900	
			9"	3635	7785	
			10"	3845	8000	
			11"	3945	8000	
			12"	4000	8000	
8-Ton Ring Clutch (8 Ton Anchor)						
8	10T	FEA08128	8"	4000	7695	16000
			9"	4165	8625	
			10"	4265	9565	
			11"	4485	10680	
			12"	4535	11660	

Safe working loads based on 4:1 Safety Factor in 3,500 psi normal weight concrete. See page 26 for Tension Vee Bar information.

Flat Steel System



Erection Anchor with Shear Plate

Welded shear plate eliminates need for shear bars.

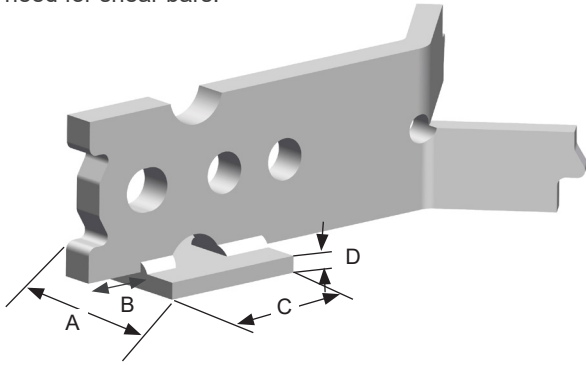

TON	SYS CODE	ITEM CODE	PLATE WIDTH (A)	PLATE POSITION (B)	PLATE LENGTH (C)	PLATE THICK. (D)
2	2.5	FEA02080S	2-1/2"	3/4"	3"	1/4"
4	5	FEA04105S	2-1/2"	1-1/4"	3"	3/8"
8	10	FEA08128S	3"	1-5/8"	3-1/2"	3/8"
10	10	FEA08128S-10T	3"	1-5/8"	3-1/2"	3/8"

TON	SYSTEM CODE	ITEM CODE	PANEL THICKNESS	SWL SHEAR W/SHEAR PLATE (LBS)	SWL TENSION W/O TENSION BAR (LBS)	SWL TENSION W/TENSION BAR (LBS)
2-Ton Ring Clutch (2 Ton Anchor)						
2	2.5T	FEA02080S	4"	1950	3190	4000
			5"	2100	3885	
			6"	2500	4000	
			7"	2870	4000	
			8"	3160	4000	
			9"	3420	4000	
			10"	3640	4000	
			11"	3840	4000	
4-Ton Ring Clutch (4 Ton Anchor)						
4	5T	FEA04105S	4"	1800	3400	8000
			5"	2660	4730	
			6"	2860	5185	
			7"	3170	6015	
			8"	3430	6900	
			9"	3650	7785	
			10"	3860	8000	
			11"	3930	8000	
8-Ton Ring Clutch (8 Ton Anchor)						
8	10T	FEA08128S	7"	4010	7100	16000
			8"	4010	7695	
			9"	4120	8625	
			10"	4280	9565	
			11"	4420	10680	
			12"	4550	11660	

Safe working loads based on approximate 4:1 Safety Factor in 3,500 psi normal weight concrete. See page 26 for Tension Vee Bar information.

Erection Split Tail Anchor

CONAC Erection Split Tail Anchor is ideal for use in thick precast wall panels and edge lifting applications. The protrusions on the anchor head prevent lifting device interaction with the concrete that could cause spalling, and enables a wider shear cone to achieve higher shear loads.

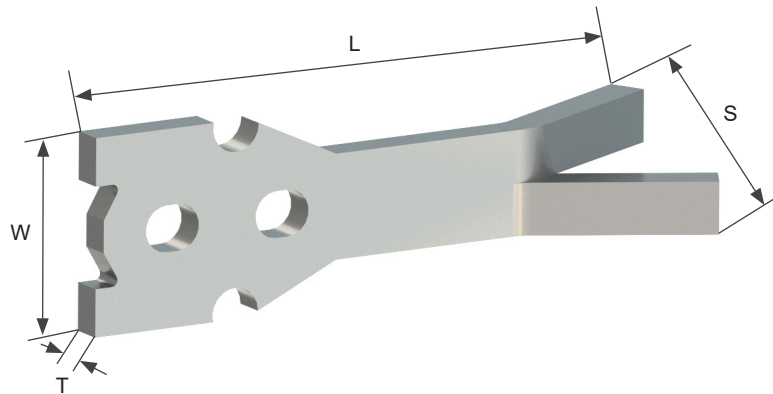

TON	SYS CODE	ITEM CODE	BODY LENGTH (L)	BODY WIDTH (W)	BODY THICK. (T)	HOLE DIA. (H)	SPREAD (S)	SWL (LBS)	UML
12.5	22	FEA-S1720	19-5/8"	5-7/8"	7/8"	1-3/8"	3-1/8"	25000	100000
17	22	FEA-S1720	19-5/8"	5-7/8"	1"	1-3/8"	3-1/8"	34000	158000
21	22	FEA-S2120	19-5/8"	5-7/8"	1-1/8"	1-3/8"	3-1/8"	42000	168000

UML=Ultimate Mechanical Load
Safe working loads based on approximate 4:1 Safety Factor in 3,500 psi normal weight concrete.

TON	SYS CODE	ITEM CODE	MIN. EDGE DISTANCE	MIN. ANCHOR SPACING	PANEL THICKNESS	SWL SHEAR W/SHEAR BAR (LBS)	SWL TENSION W/TENSION BAR (LBS)
12.5	22	FEA-S1720	36"	72"	10"	10538	25000
17	22	FEA-S1720	36"	72"	12"	14332	34000
21	22	FEA-S2120	36"	72"	14"	18547	42000

UML=Ultimate Mechanical Load
Safe working loads based on approximate 4:1 Safety Factor in 3,500 psi normal weight concrete.

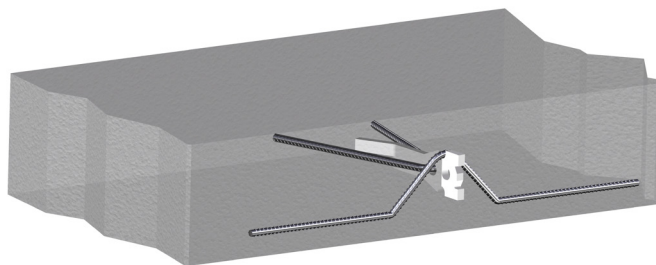

TON	SHEAR BAR	
	REBAR SIZE (DIA)	REBAR LENGTH (BEFORE BENDING)
12.5	#8	72"
17	#8	72"
21	#8	72"

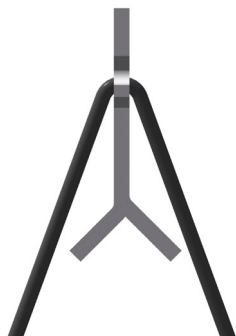

Rebar V's are required to develop SWL.

TENSION VEES	REBAR SIZE	MIN. BEND DIAMETER (D)	REQUIRED TO DEVELOP REINFORCED ALLOWABLE TENSION CAPACITY						
			Concrete Strength [psi]						
Nominal System Capacity			2,200	2,500	3,000	3,500	4,000	4,500	5,000
			Length of Rebar Before Bending [in]						
12.5 Ton	#7	5-1/4"	110	104	95	89	83	79	75
17 Ton	#8	6"	130	122	112	105	98	93	89
21 Ton	#9	9-1/2"	143	134	123	115	108	102	97

Based on ACI 318-14 requirements.
For single bar application.
Multiply chart values by 1.3 for lightweight concrete.
Multiply chart values by 1.2 for epoxy coated bars.

Flat Steel System



Forged Erection Anchor

Designed to edge lift panel to vertical position with use of shear bar or shear plate.

See page 39 for shear bar information.

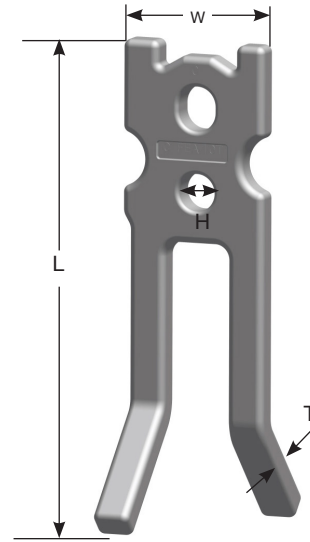
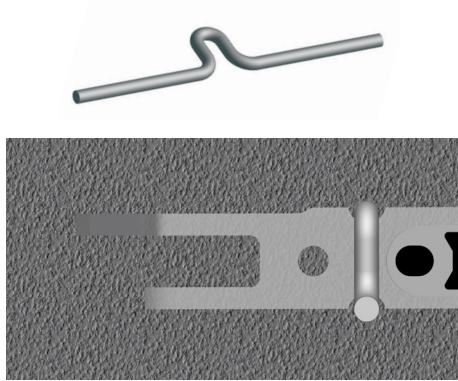

TON	SYS CODE	RING CLUTCH	ITEM CODE	BODY LENGTH (L)	BODY WIDTH (W)	BODY THICK. (T)	HOLE DIA. (H)	SPREAD (S)	SWLTENSION (LBS)	UML (LBS)
3	2.5T	2-3 T	CFEA3T	8"	2"	3/8"	1/2"	3-1/4"	6,000	24,000
6	5.0T	4-6 T	CFEA6T	10-1/2"	2-3/4"	5/8"	3/4"	4-3/16"	12,000	48,000
11	10T	11 T	CFEA11T*	12-13/16"	4"	3/4"	1-1/8"	6"	24,000	96,000

Safe working loads based on approximate 4:1 Safety Factor in 3,500 psi normal weight concrete.

UML=Ultimate Mechanical Load

* Note: Using this anchor to its 11 ton capacity requires use of CONAC FRC11B Ring Clutch.



Rebar V's are required to develop SWL.

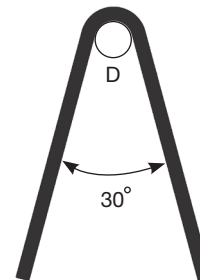

TENSION VEES		REQUIRED TO DEVELOP REINFORCED ALLOWABLE TENSION CAPACITY							
Nominal System Capacity	Rebar Size	Min. Bend Diameter (D)	Concrete Strength [psi]						
			2,200	2,500	3,000	3,500	4,000	4,500	
			Length of Rebar Before Bending [in]						
3 Ton	#4	3"	37	35	32	30	28	27	25
6 Ton	#5	3-3/4"	59	56	51	48	45	43	41
11 Ton	#7	5-1/4"	97	91	84	78	73	69	66
12 Ton	#7	5-1/4"	106	100	91	85	80	76	72

Based on ACI 318-14 requirements.

For single bar application.

Multiply chart values by 1.3 for lightweight concrete.

Multiply chart values by 1.2 for epoxy coated bars.

Forged Erection Anchor With Shear Plate

Shear plate eliminates need for shear bars.

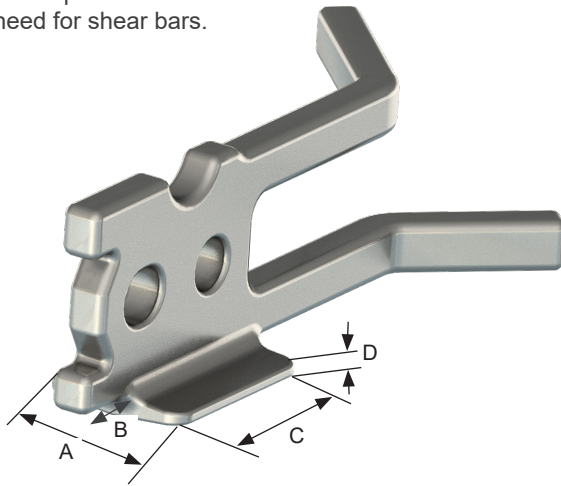

TON	SYS CODE	ITEM CODE	PLATE WIDTH (A)	PLATE POSITION (B)	PLATE LENGTH (C)	PLATE THICK. (D)
3	2.5	CFEA3TS	2-1/2"	3/4"	3-1/2"	5/16"
6	5	CFEA6TS	2-1/2"	1-1/4"	3"	3/8"
11	10	CFEA11TS	3"	1-5/8"	4"	3/8"

TON	SYSTEM CODE	ITEM CODE	PANEL THICKNESS	SWL SHEAR W/SHEAR PLATE (LBS)	SWL TENSION W/O TENSION BAR (LBS)	SWL TENSION W/TENSION BAR (LBS)
2-3 Ton Ring Clutch (3 Ton Anchor)						
3	2.5T	CFEA3TS	4"	1980	3190	6000
			5"	2110	3885	
			6"	2360	4000	
			7"	2610	4380	
			8"	2880	5010	
			9"	3160	5640	
			10"	3440	6000	
			11"	3720	6000	
4-6 Ton Ring Clutch (6 Ton Anchor)						
6	5.0T	CFEA6TS	5-1/2"	2840	4970	12000
			6"	2980	5185	
			7"	3260	6015	
			8"	3550	6900	
			9"	3850	7785	
			10"	4160	8590	
			11"	4480	9450	
			12"	4800	10310	
11-Ton Ring Clutch (11 Ton Anchor)						
11	10T	CFEA11TS	8"	3800	7695	24000
			9"	4100	8625	
			10"	4410	9565	
			11"	4730	10680	
			12"	5060	11660	

Safe working loads based on approximate 4:1 Safety Factor in 3,500 psi normal weight concrete.

Flat Steel System



Forged Erection Anchor With Shear Plate

Designed to edge lift panel to vertical position. Shear plate eliminates need for shear bars.

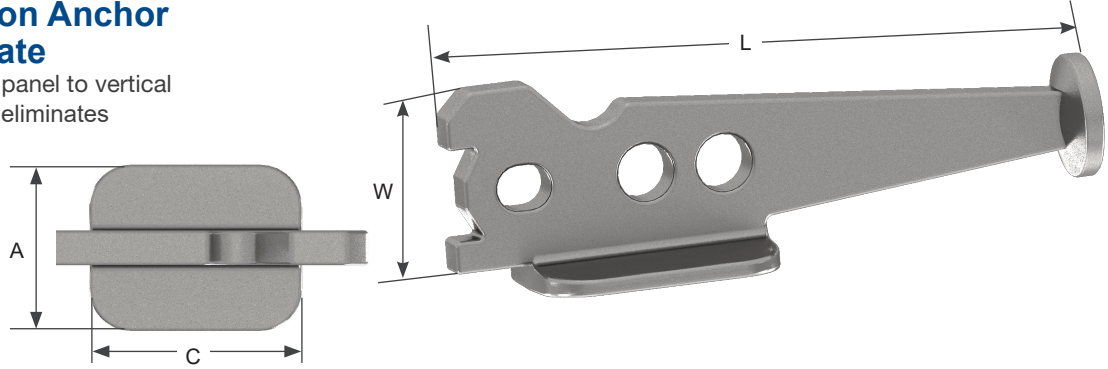

TON	SYS CODE	RING CLUTCH	ITEM CODE	BODY LENGTH (L)	BODY WIDTH (W)	BODY THICK. (T)	PLATE WIDTH (A)	PLATE LENGTH (C)	SWL TENSION (LBS)	UML (LBS)
3	2.5T	2-3 T	CNFEA3TS	8"	2-3/8"	3/8"	2-1/2"	3-1/2"	6000	24000
6	5.0T	4-6 T	CNFEA6TS	10-1/2"	2-7/8"	5/8"	3"	4"	12000	48000
12	10T	12 T	CNFEA12TS	12-13/16"	4-5/16"	3/4"	3-1/4"	4"	24000	96000

UML=Ultimate Mechanical Load
Safe working loads based on approximate 4:1 Safety Factor in 3,500 psi normal weight concrete.

TON	SYSTEM CODE	ITEM CODE	PANEL THICKNESS	SWL SHEAR W/SHEAR PLATE (LBS)	SWL TENSION W/O TENSION BAR (LBS)	SWL TENSION W/TENSION BAR (LBS)
2-3 Ton Ring Clutch						
3	2.5T	CNFEA3TS	4"	1800	6000	6000
			5"	2300		
			6"	2800		
			7"	3400		
			8"	4000		
			9"	4400		
			10"	4800		
			11"	5200		
12"	5700					
4-6 Ton Ring Clutch						
6	5.0T	CNFEA6TS	5-1/2"	3100	10000	12000
			6"	3250		
			7"	3700		
			8"	4040		
			9"	4600		
			10"	5000		
			11"	5500		
			12"	6100		
12 Ton Ring Clutch						
12	10T	CNFEA12TS	7-1/2"	4600	17890	24000
			8"	4800		
			9"	5450		
			10"	6100		
			11"	6800		
			12"	7600		

Safe working loads based on approximate 4:1 Safety Factor in 3,500 psi normal weight concrete.

Flat Steel System

Tech Erection Anchor

Designed to edge lift panel to vertical position with use of shear bar or shear plate. Indentations in the sides of the anchor increase bond to develop additional tension load when Tension "V" is not in use. Tension "V"s are still necessary to develop the full mechanical capacity of the anchor.

See page 39 for shear bar information.

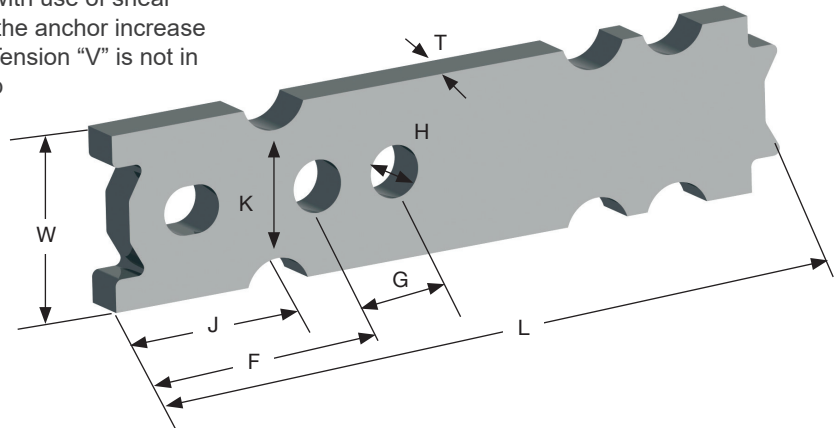
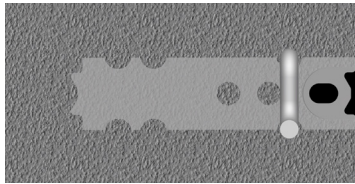

TON	SYS CODE	ITEM CODE	BODY LENGTH (L)	BODY WIDTH (W)	BODY THICK. (T)	NOTCH LOCATION (J)	NECK WIDTH (K)	HOLE LOCA. (F)	HOLE CENTER (G)	HOLE DIA. (H)	SWL TENSION (LBS)	UML TENSION (LBS)
2	2.5	FEA-T02080	8"	2"	3/8"	1-13/16"	1-3/8"	2-1/4"	1-1/8"	9/16"	4,000	16,000
4	5	FEA-T04105	10-1/2"	2-1/2"	5/8"	2-1/2"	1-13/16"	3-3/16"	1-1/4"	3/4"	8,000	32,000
8	10	FEA-T08128	13-3/8"	3-3/4"	3/4"	3-3/16"	2-9/16"	4"	1-3/4"	1"	16,000	64,000

Safe working loads based on approximate 4:1 Safety Factor in 3,500 psi normal weight concrete.
UML= Ultimate Mechanical Load

TON	SYSTEM CODE	ITEM CODE	PANEL THICKNESS	SWL SHEAR W/SHEAR BAR (LBS)	SWL TENSION W/O TENSION BAR (LBS)	SWL TENSION W/TENSION BAR (LBS)
2-Ton Ring Clutch (2 Ton Anchor)						
2	2.5T	FEA-T02080	4"	1950	3190	4000
			5"	2105	3885	
			6"	2535	4000	
			7"	2885	4000	
			8"	3145	4000	
			9"	3445	4000	
			10"	3625	4000	
			11"	3885	4000	
4-Ton Ring Clutch (4 Ton Anchor)						
4	5T	FEA-T04105	6"	3000	5185	8000
			7"	3155	6015	
			8"	3445	6900	
			9"	3635	7785	
			10"	3845	8000	
			11"	3945	8000	
			12"	4000	8000	
8-Ton Ring Clutch (8 Ton Anchor)						
8	10T	FEA-T08128	8"	4000	7695	16000
			9"	4165	8625	
			10"	4265	9565	
			11"	4485	10680	
			12"	4535	11660	

Safe working loads based on approximate 4:1 Safety Factor in 3,500 psi normal weight concrete.
See page 26 for Tension Vee Bar information.

Flat Steel System



Tech Erection Anchor with Shear Plate

Welded shear plate eliminates need for shear bars.

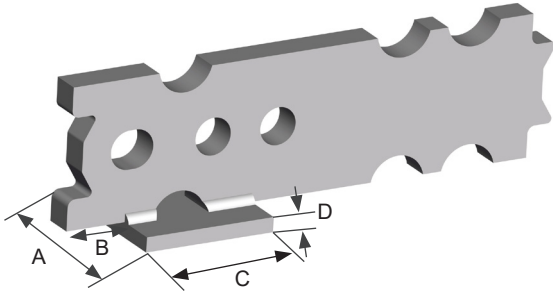

TON	SYS CODE	ITEM CODE	PLATE WIDTH (A)	PLATE POSITION (B)	PLATE LENGTH (C)	PLATE THICK. (D)
2	2.5	FEA-T02080S	2-1/2"	3/4"	3"	1/4"
4	5	FEA-T04105S	2-1/2"	1-1/4"	3"	3/8"
8	10	FEA-T08128S	3"	1-5/8"	3-1/2"	3/8"

TON	SYSTEM CODE	ITEM CODE	PANEL THICKNESS	SWL SHEAR W/SHEAR PLATE (LBS)	SWL TENSION W/O TENSION BAR (LBS)	SWL TENSION W/TENSION BAR (LBS)
2-Ton Ring Clutch (2 Ton Anchor)						
2	2.5T	FEA-T02080S	4"	1950	3190	4000
			5"	2100	3885	
			6"	2500	4000	
			7"	2870	4000	
			8"	3160	4000	
			9"	3420	4000	
			10"	3640	4000	
			11"	3840	4000	
4-Ton Ring Clutch (4 Ton Anchor)						
4	5T	FEA-T04105S	4"	1800	3400	8000
			5"	2660	4730	
			6"	2860	5185	
			7"	3170	6015	
			8"	3430	6900	
			9"	3650	7785	
			10"	3860	8000	
			11"	3930	8000	
8-Ton Ring Clutch (8 Ton Anchor)						
8	10T	FEA-T08128S	7"	4010	7100	16000
			8"	4010	7695	
			9"	4120	8625	
			10"	4280	9565	
			11"	4420	10680	
			12"	4550	11660	

Safe working loads based on approximate 4:1 Safety Factor in 3,500 psi normal weight concrete. See page 26 for Tension Vee Bar information.

Erection Head Anchor

Ideal for lifting in shear position, such as a tilt table or A-frame when shear plate or shear bar is used.
Rebar V's are required to develop SWL.

See page 39 for shear bar information.

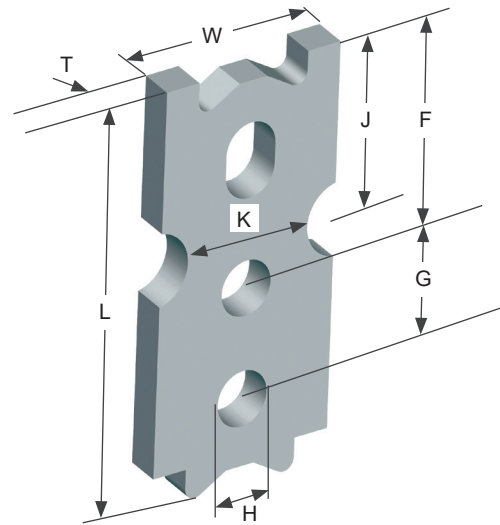
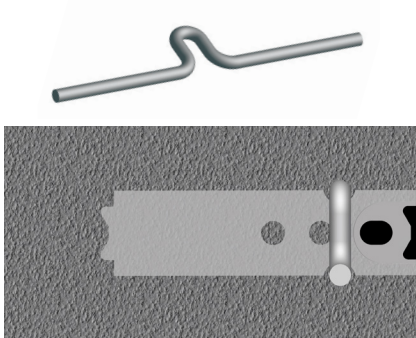

TON	SYS CODE	ITEM CODE	BODY LENGTH (L)	BODY WIDTH (W)	BODY THICK. (T)	NOTCH LOCATION (J)	NECK WIDTH (K)	HOLE LOCA. (F)	HOLE CENTER (G)	HOLE DIA. (H)	SWL TENSION (LBS)	UML (LBS)
2	2.5	FEH02043	4-1/4"	2"	3/8"	1-13/16"	1-3/8"	2-1/4"	1-1/8"	9/16"	4,000	16000
2	2.5	FEH02080	7-7/8"	2"	3/8"	1-13/16"	1-3/8"	2-1/4"	1-1/8"	9/16"	4,000	16000
4	5	FEH04075	7-7/16"	2-1/2"	5/8"	2-1/2"	1-13/16"	3-3/16"	1-1/4"	3/4"	8,000	32000
4	5	FEH04105	10-1/2"	2-1/2"	5/8"	2-1/2"	1-13/16"	3-3/16"	1-1/4"	3/4"	8,000	32000
8	10	FEH08133	13-1/4"	3-3/4"	3/4"	3-1/8"	2-7/16"	4"	1-3/4"	1"	16,000	64000

Safe working loads based on approximate 4:1 Safety Factor in 3,500 psi normal weight concrete.
 UML= Ultimate Mechanical Load

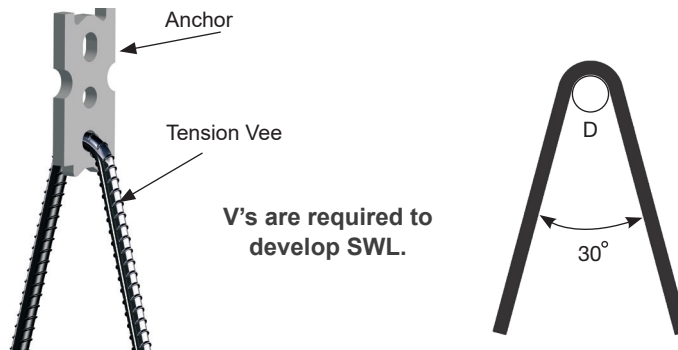

TENSION VEES		REQUIRED TO DEVELOP REINFORCED ALLOWABLE TENSION CAPACITY							
Nominal System Capacity	Rebar Size	Min. Bend Diameter (D)	Concrete Strength [psi]						
			2,200	2,500	3,000	3,500	4,000	4,500	5,000
			Length of Rebar Before Bending [in]						
2 Ton	#3	2-1/4"	33	32	29	27	25	24	24
4 Ton	#4	3"	49	46	43	40	37	35	34
8 Ton	#6	4-1/2"	67	63	58	54	51	48	46
10 Ton	#7	5-1/4"	88	83	76	71	67	63	60

Based on ACI 318-14 requirements.
 For single bar application.
 Multiply chart values by 1.3 for lightweight concrete.
 Multiply chart values by 1.2 for epoxy coated bars.

Flat Steel System



Erection Head Anchor with Shear Plate

Welded shear plate eliminates need for shear bars.

TON	SYS CODE	ITEM CODE	PLATE WIDTH (A)	PLATE POSITION (B)	PLATE LENGTH (C)	PLATE THICK. (D)
2	2.5	FEH02043S	2-1/2"	3/4"	3"	1/4"
2	2.5	FEH02080S	2-1/2"	3/4"	3"	1/4"
4	5	FEH04075S	2-1/2"	1-1/4"	3"	3/8"
4	5	FEH04105S	2-1/2"	1-1/4"	3"	3/8"
8	10	FEH08133S	3"	1-5/8"	3-1/2"	3/8"

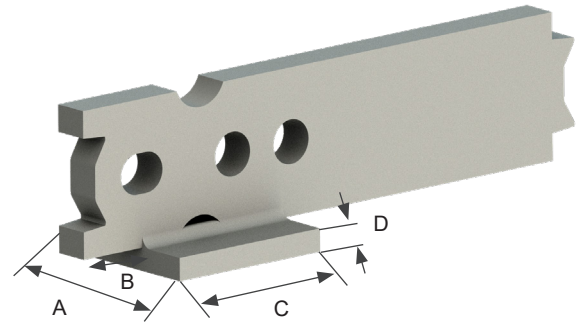

TON	SYSTEM CODE	ITEM CODE	PANEL THICKNESS	SWL SHEAR W/SHEAR PLATE (LBS)	SWL TENSION W/TENSION BAR (LBS)
2-Ton Ring Clutch (2 Ton Anchor)					
2	2.5	FEH02043S	4"	1235	4000
			5"	1525	
			6"	1750	
			7"	1900	
			8"	2075	
2	2.5T	FEH02080S	4"	1950	4000
			5"	2100	
			6"	2500	
			7"	2870	
			8"	3160	
4-Ton Ring Clutch (4 Ton Anchor)					
4	5T	FEH04075S	5-1/2"	2025	8000
			6"	2250	
			7"	2600	
			8"	3000	
			9"	3375	
			10"	3750	
4	5T	FEH04105S	5"	2660	8000
			6"	2920	
			7"	3170	
			8"	3430	
			9"	3650	
			10"	3860	
			11"	3930	
12"	4010				
8-Ton Ring Clutch (8 Ton Anchor)					
8	10T	FEH08133S	7"	4010	16000
			8"	4010	
			9"	4120	
			10"	4280	
			11"	4420	
			12"	4550	

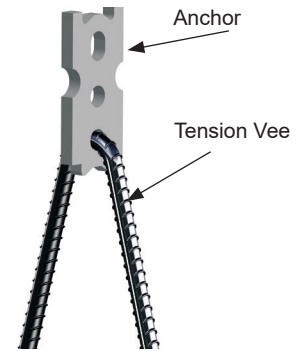

V's are required to develop SWL.

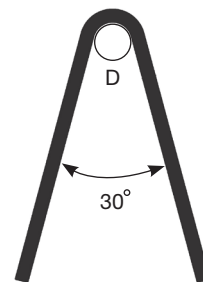

Safe working loads based on approximate 4:1 Safety Factor in 3,500 psi normal weight concrete. See page 26 for Tension Vee Bar information.

Flat Steel System

Insulated Panel Erection Anchor

Used for insulated/sandwich wall panels. Delivers load distribution to both wythes. Shear plate maximizes shear loads. Rebar Vees required to develop SWL.

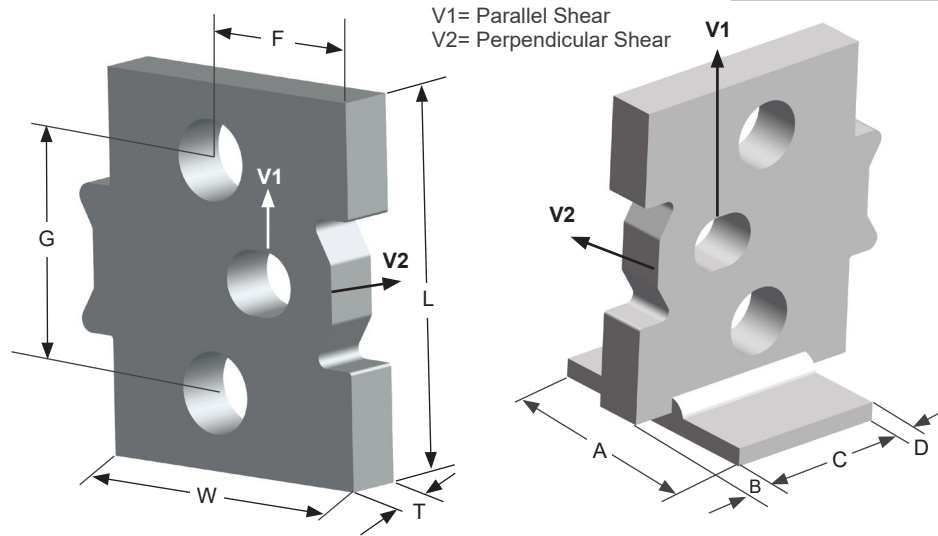

TON	ITEM CODE	ANCH. LENG. (L)	ANCH. WIDTH (W)	THICK. (T)	HOLE LOCAT. (F)	HOLE CENT. (G)	PLATE WIDTH (A)	PLATE POS. (B)	PLATE LENG. (C)	PLATE THICK. (D)	UML TENS. (LBS)	SWL TENS. (LBS)	V1 SHEAR (LBS)	V2 SHEAR (LBS)
FOR 6" THICK PANEL 2+2+2														
4	FIN043X4	4"	3-3/8"	5/8"	2-1/4"	2-3/8"	n/a	n/a	n/a	n/a	32000	6400	3640	3700
4	FIN043X4S	4"	3-3/8"	5/8"	2-1/4"	2-3/8"	3"	1/2"	2"	1/4"	32000	6400	3605	3700
FOR 8" THICK PANEL 3+2+3														
4	FIN 043X6	6"	3-1/4"	5/8"	1-7/8"	4-3/8"	n/a	n/a	n/a	n/a	32000	8000	4600	8000
4	FIN043X6S	6"	3-1/4"	5/8"	1-7/8"	4-3/8"	3"	5/8"	2"	1/4"	32000	8000	4875	8000
8	FIN084X6	6"	4-3/4"	3/4"	3-3/8"	4-3/8"	n/a	n/a	n/a	n/a	64000	16000	4310	9500
8	FIN084X6S	6"	4-3/4"	3/4"	3-3/8"	4-3/8"	3"	3/4"	3-1/2"	3/8"	64000	16000	4409	9500
FOR 8" THICK PANEL 4+2+2														
4	FIN043X6	6"	3-1/4"	5/8"	1-7/8"	4-3/8"	n/a	n/a	n/a	n/a	32000	8000	5050	8000
4	FIN043X6S	6"	3-1/4"	5/8"	1-7/8"	4-3/8"	3"	5/8"	2"	1/4"	32000	8000	5350	8000
8	FIN084X6	6"	4-3/4"	3/4"	3-3/8"	4-3/8"	n/a	n/a	n/a	n/a	64000	16000	5110	10500
8	FIN084X6S	6"	4-3/4"	3/4"	3-3/8"	4-3/8"	3"	3/4"	3-1/2"	3/8"	64000	16000	5427	10500
FOR 9" THICK PANEL 3+3+3														
10	FIN084X7	7"	4-3/4"	3/4"	3-3/8"	5"	n/a	n/a	n/a	n/a	80000	20000	5210	10900
10	FIN084X7S	7"	4-3/4"	3/4"	3-3/8"	5"	8"	1"	3"	3/8"	80000	20000	5520	10900
FOR 10" THICK PANEL 3+4+3														
10	FIN084X8	8"	4-3/4"	3/4"	3-3/8"	6"	n/a	n/a	n/a	n/a	80000	20000	4910	9700
10	FIN084X8S	8"	4-3/4"	3/4"	3-3/8"	6"	8"	1"	3"	3/8"	80000	20000	5210	9700

Safe working loads based on approximate 4:1 Safety Factor in 3,500 psi (4,500 psi for 10T anchors) normal weight concrete. UML= Ultimate Mechanical Load

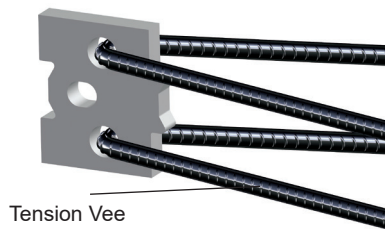

Tension Vee

Based on ACI 318-14 requirements. For two-bar application. Multiply chart values by 1.3 for lightweight concrete. Multiply chart values by 1.2 for epoxy coated bars.

TENSION VEES	REQUIRED TO DEVELOP REINFORCED ALLOWABLE TENSION CAPACITY								
	Nominal System Capacity	Rebar Size	Min. Bend Diameter (D)	Concrete Strength [psi]					
				2,200	2,500	3,000	3,500	4,000	4,500
				Length of Rebar Before Bending [in]					
4 Ton	2 #4s	3"	37	35	32	30	30	30	30
6 Ton	2 #4s	3"	55	52	48	45	42	40	38
8 Ton	2 #5s	3-3/4"	59	56	51	48	45	43	41
9 Ton	2 #5s	3-3/4"	67	75	69	65	61	58	55
10 Ton	2 #6s	4-1/2"	63	59	54	51	48	45	43
12 Ton	2 #6s	4-1/2"	75	71	65	61	57	54	52

Flat Steel System



Forged Insulated Panel Erection Anchor

CONAC's CFIN Forged Insulated Panel Erection Anchor is designed for use in insulated panels. The design spans the insulation with minimal effect on thermal efficiency and achieves even load distribution throughout both wythes for optimal performance. The forging process ensures higher anchor strength and increased load capacity. Use of tension rebar V's is required to achieve full SWL, and shear bars develop maximum shear capacity.

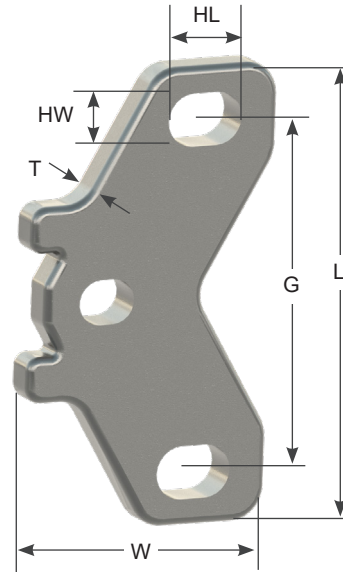

TON	RING CLUTCH	ITEM CODE	LENGTH (L)	WIDTH (W)	THICK. (T)	HOLE CENT. (G)	HOLE LENGTH (HL)	HOLE WIDTH (HW)	UML TENSION (LBS)
6	4-6 T	CFIN6T	7"	4"	5/8"	5-3/8"	1-3/16"	13/16"	48000
9	8-11 T	CFIN9T	5-3/4"	4-3/16"	3/4"	3-3/4"	1-1/2"	15/16"	72000
12	12 T	CFIN12X7	7"	4-13/16"	3/4"	5"	1-13/16"	1-1/8"	96000
12	12 T	CFIN12X8	8"	4-13/16"	3/4"	6"	1-13/16"	1-1/8"	96000

UML= Ultimate Mechanical Load

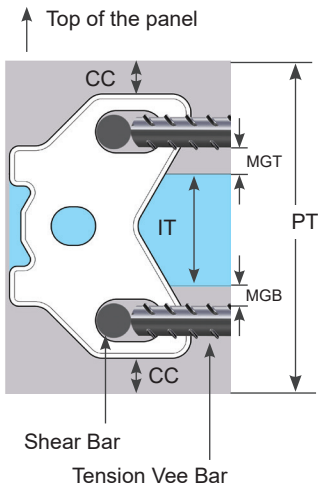

ITEM CODE	LENGTH (L)	PANEL THICKNESS	BOTTOM WYTHE	INSUL. THICK.	TOP WYTHE	MGT	MGB	CONCRETE COVER
CFIN6T	7"	8"	2"	4"	2"	7/16"	7/16"	1/2"
		9"	3"	3"	3"	15/16"	15/16"	1"
CFIN9T	5-3/4"	8"	3"	2"	3"	9/16"	9/16"	1-1/8"
CFIN12X7	7"	9"	3"	3"	3"	5/8"	5/8"	1"
CFIN12X8	8"	10"	3"	4"	3"	5/8"	5/8"	1"
		11"	2-1/2"	4"	2-1/2"	5/8"	5/8"	1/2"

Minimum 1/2" concrete cover required on top and bottom of Insulated Panel Anchor.

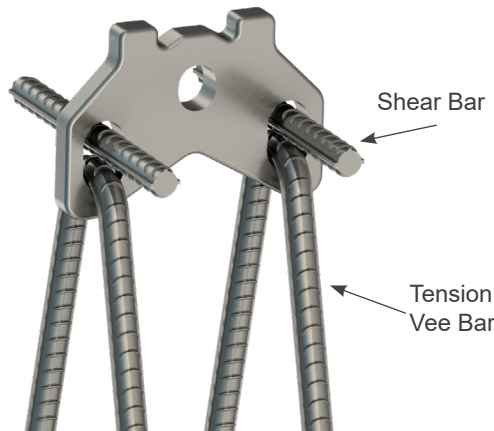

Flat Steel System

Forged Insulated Panel Erection Anchor Load Chart

TON	ITEM CODE	V1 SHEAR 4:1 (LBS)	V1 SHEAR 2.66:1 (LBS)	V2 SHEAR 4:1 (LBS)	SWL TENSION 4:1 (LBS)	UML TENSION (LBS)	TENSION REBAR GR 60	SHEAR REBAR GR 60
FOR 8" THICK PANEL 2+4+2								
6	CFIN6T	2670	4020	8200	12000	48000	#4 x 45"	#5 x 6"

Safe working loads based on approximate 4:1 Safety Factor in 3,500 psi for 6 T anchor and 4,500 psi for 9T and 12T anchors normal weight concrete.

2.66:1 safety factor in shear may be used at the discretion of the engineer for stripping.

V1= Parallel Shear

V2= Perpendicular Shear

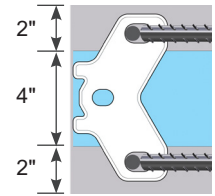

6 Ton Forged Anchor for 8" Panel

TON	ITEM CODE	V1 SHEAR 4:1 (LBS)	V1 SHEAR 2.66:1 (LBS)	V2 SHEAR 4:1 (LBS)	SWL TENSION 4:1 (LBS)	UML TENSION (LBS)	TENSION REBAR GR 60	SHEAR REBAR GR 60
FOR 8" THICK PANEL 4+2+2								
9	CFIN9T	4600	6910	9260	18000	72000	#5 x 58"	#6 x 6"
FOR 8" THICK PANEL 3+2+3								
9	CFIN9T	4400	6610	8700	18000	72000	#5 x 58"	#6 x 6"

Safe working loads based on approximate 4:1 Safety Factor in 3,500 psi for 6 T anchor and 4,500 psi for 9T and 12T anchors normal weight concrete.

2.66:1 safety factor in shear may be used at the discretion of the engineer for stripping.

V1= Parallel Shear

V2= Perpendicular Shear

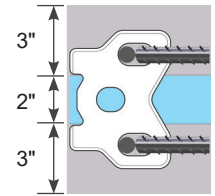

9 Ton Forged Anchor for 8" Panel

TON	ITEM CODE	V1 SHEAR 4:1 (LBS)	V1 SHEAR 2.66:1 (LBS)	V2 SHEAR 4:1 (LBS)	SWL TENSION 4:1 (LBS)	UML TENSION (LBS)	TENSION REBAR GR 60	SHEAR REBAR GR 60
FOR 9" THICK PANEL 3+3+3								
6	CFIN6T	4500	6780	9600	12000	48000	#4 x 45"	#5 x 6"
12	CFIN12X7	4700	7060	10900	24000	96000	#6 x 54"	#7 x 6"

Safe working loads based on approximate 4:1 Safety Factor in 3,500 psi for 6 T anchor and 4,500 psi for 9T and 12T anchors normal weight concrete.

2.66:1 safety factor in shear may be used at the discretion of the engineer for stripping.

V1= Parallel Shear

V2= Perpendicular Shear

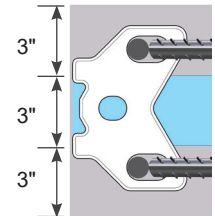

12 Ton Forged Anchor for 9" Panel

TON	ITEM CODE	V1 SHEAR 4:1 (LBS)	V1 SHEAR 2.66:1 (LBS)	V2 SHEAR 4:1 (LBS)	SWL TENSION 4:1 (LBS)	UML TENSION (LBS)	TENSION REBAR GR 60	SHEAR REBAR GR 60
FOR 10" THICK PANEL 3+4+3								
12	CFIN12X8	4400	6610	9200	24000	96000	#6 x 54"	#7 x 6"

Safe working loads based on approximate 4:1 Safety Factor in 3,500 psi for 6 T anchor and 4,500 psi for 9T and 12T anchors normal weight concrete.

2.66:1 safety factor in shear may be used at the discretion of the engineer for stripping.

V1= Parallel Shear

V2= Perpendicular Shear

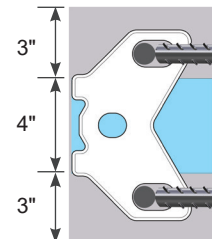

12 Ton Forged Anchor for 10" Panel

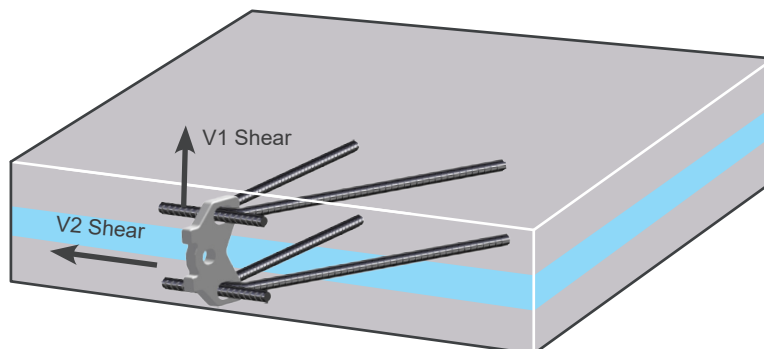

Flat Steel System



Two Hole Anchor

Lower hole accommodates rebar V's which are required to develop the SWL. Use only in tension.

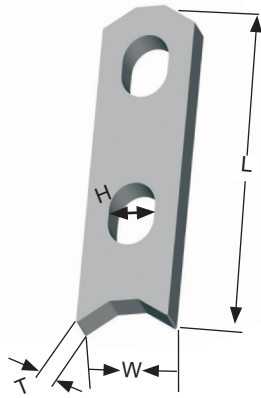

TON	SYS CODE	ITEM CODE	ANCHOR LENGTH (L)	REBAR HOLE (H)	BODY THICK. (T)	BODY WIDTH (W)	SWL TENSION (LBS)	UML (LBS)
2	2.5	FTH02040	4"	5/8"	3/8"	1-1/4"	4000	16000
2	2.5	FTH02028	2-3/4"	9/16"	3/8"	1-1/4"	4000	16000
4	5	FTH04040	4"	5/8"	5/8"	1-1/2"	8000	32000
4	5	FTH04055	5-1/2"	11/16"	5/8"	1-1/2"	8000	32000
8	10	FTH08070	7"	1"	3/4"	2-1/2"	16000	64000
22	22	FTH22118	11-3/4"	1-1/2"	1"	3-3/4"	44000	176000

UML= Ultimate Mechanical Load

Safe working loads based on approximate 4:1 Safety Factor in 3,500 psi normal weight concrete.

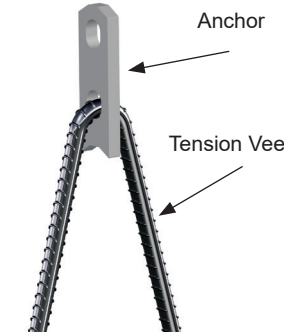

V's are required to develop SWL.

TENSION VEES		REQUIRED TO DEVELOP REINFORCED ALLOWABLE TENSION CAPACITY						
		Concrete Strength [psi]						
Nominal System Capacity	Rebar Size	2,200	2,500	3,000	3,500	4,000	4,500	5,000
		Length of Rebar Before Bending [in]						
2 Ton	#3	33	32	29	27	25	24	24
4 Ton	#4	49	46	43	40	37	35	34
8 Ton	#6	67	63	58	54	51	48	46
10 Ton	#7	88	83	76	71	67	63	60
22 Ton	#9	150	141	129	120	113	107	102

Based on ACI 318-14 requirements.

For single bar application.

Multiply chart values by 1.3 for lightweight concrete.

Multiply chart values by 1.2 for epoxy coated bars.

Two Hole Tech Anchor

Indentations in the sides of the anchor increase bond to develop additional tensile capacity without the tension "V"s.

(Tension "V"s are still necessary to develop the full mechanical capacity of the anchor). Use only in tension.

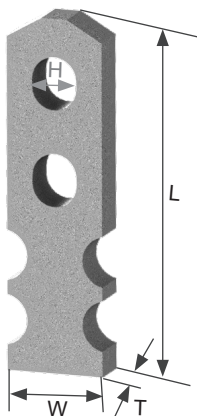

TON	SYS CODE	ITEM CODE	ANCHOR LENGTH (L)	REBAR HOLE (H)	BODY THICK. (T)	BODY WIDTH (W)	SWL TENSION (LBS)	UML (LBS)
2	2.5	FTH-T02050	4-15/16"	5/8"	3/8"	1-1/4"	4000	16000
4	5	FTH-T04055	5-7/16"	5/8"	5/8"	1-1/2"	8000	32000

UML= Ultimate Mechanical Load

Safe working loads based on approximate 4:1 Safety Factor in 3,500 psi normal weight concrete.

Spread Anchor

Used for both stripping and erecting. With proper edge distances can be pulled in any direction.

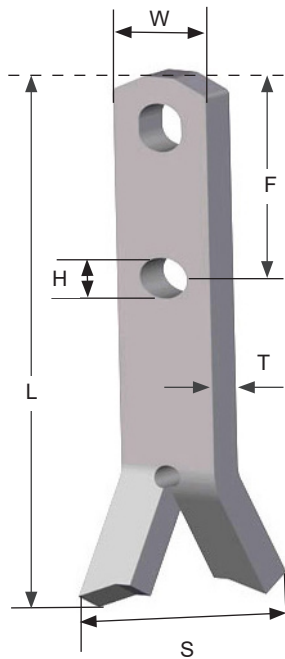

TON	SYS CODE	ITEM CODE	BODY LENGTH (L)	BODY WIDTH (W)	BODY THICK. (T)	BASE SPREAD (S)	HOLE LOCA. (F)	HOLE DIA. (H)	MIN EDGE DIST.	SWL TENSION (LBS)	SWL TENSION W/TENSION BAR (LBS)
1	2.5	FSP02048	4-3/4"	1-1/4"	3/16"	2-3/4"	N/A	N/A	5-3/8"	2000	2000
2	2.5	FSP02040	4"	1-1/4"	3/8"	2-3/4"	N/A	N/A	4-5/8"	2993	4000
2	2.5	FSP02055	5-1/2"	1-1/4"	3/8"	2-3/4"	2-1/4"	1/2"	6-1/8"	4000	4000
4	5	FSP04040	4"	1-1/2"	1/2"	3-3/8"	N/A	N/A	4-3/4"	2994	8000
4	5	FSP04048	4-3/4"	1-1/2"	1/2"	3-3/8"	N/A	N/A	5-1/2"	3805	8000
4	5	FSP04068	6-3/4"	1-1/2"	1/2"	3-3/8"	3-3/4"	7/8"	7-1/2"	6262	8000
4	5	FSP04063	6-1/4"	1-1/2"	5/8"	3-3/8"	3-3/4"	11/16"	7-1/8"	5703	8000
4	5	FSP04095	9-1/2"	1-1/2"	5/8"	3-3/8"	3-3/4"	11/16"	10-1/4"	8000	8000
6	10	FSP06110	11"	2-1/2"	5/8"	5-1/4"	5"	1"	12-1/4"	12000	12000
8	10	FSP08110	11"	2-1/2"	3/4"	5-1/4"	5"	1"	12-1/4"	12859	16000
16	22	FSP22150	15"	3-3/4"	1"	6-1/4"	7-1/2"	1-3/8"	16-5/8"	21593	32000
22	22	FSP22189	18-7/8"	3-3/4"	1"	6-1/4"	13"	1-3/8"	20-1/2"	31042	44000

Safe working loads based on approximate 4:1 Safety Factor in 3,500 psi normal weight concrete.

V's are required to develop SWL.

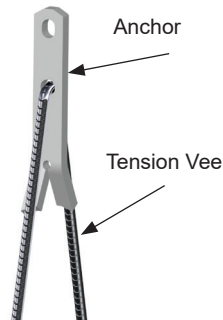

TENSION VEES	REQUIRED TO DEVELOP REINFORCED ALLOWABLE TENSION CAPACITY							
	Rebar Size	Concrete Strength [psi]						
		2,200	2,500	3,000	3,500	4,000	4,500	5,000
Nominal System Capacity								
		Length of Rebar Before Bending [in]						
2 Ton	#3	33	32	29	27	25	24	24
4 Ton	#4	49	46	43	40	37	35	34
8 Ton	#6	67	63	58	54	51	48	46
10 Ton	#7	88	83	76	71	67	63	60
16 Ton	#8	130	122	112	105	98	93	89
22 Ton	#9	150	141	129	120	113	107	102

Based on ACI 318-14 requirements.

For single bar application.

Multiply chart values by 1.3 for lightweight concrete.

Multiply chart values by 1.2 for epoxy coated bars.

L-Anchor

Used for back stripping precast panels.

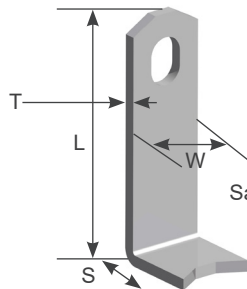

TON	SYS CODE	ITEM CODE	ANCHOR LENGTH (L)	BODY WIDTH (W)	BODY THICK. (T)	FOOT LENGTH (S)	SWL TENSION (LBS)	UML (LBS)
1	2.5	FL 1-1/4"X4"	4"	1-1/4"	3/16"	1-1/2"	2000	8000

Safe working loads based on approximate 4:1 Safety Factor in 3,500 psi normal weight concrete.

UML= Ultimate Mechanical Load

Flat Steel System



Plate Anchor (Square Base)

The CONAC FPA-S Series Anchors have been developed with a large square base, increasing the shear cone within the concrete and eliminating the requirement for additional rebar reinforcement over the base plate in achieving the listed SWL.

TON	SYS CODE	ITEM CODE	ANCHOR DEPTH (L)	BODY WIDTH (W)	BODY THICK. (T)	BASE THICK. (B)	BASE WIDTH (A)	BASE LENGTH (C)	MIN EDGE DIST.	SWL TENSION (LBS)	SWL SHEAR (LBS)	UML (LBS)
4	5	FPA-S043916	3-9/16"	1-1/2"	5/8"	3/8"	3"	3"	7-1/2"	5500	5500	32000
4	5	FPA-S044916	4-9/16"	1-1/2"	5/8"	3/8"	3"	3"	9"	7000	7000	32000
8	10	FPA-S08638	6-3/8"	2-1/2"	3/4"	5/8"	4"	4"	12-1/2"	15250	15250	64000
8	10	FPA-S08738	7-3/8"	2-1/2"	3/4"	5/8"	4"	4"	14"	16000	16000	64000

Safe working loads based on approximate 4:1 Safety Factor in 3,500 psi normal weight concrete.

UML= Ultimate Mechanical Load



When used in shear, the load should be perpendicular to the face of the anchor.

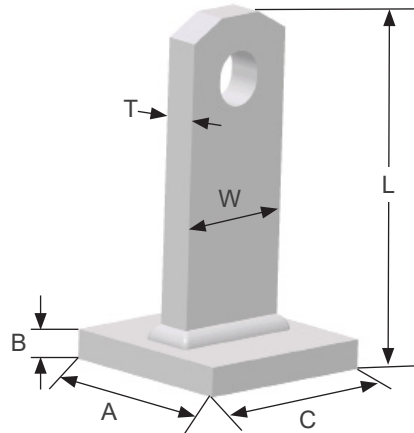

The larger square base allows achieving listed SWL without additional rebar reinforcement over the base plate.

Plate Anchor

Bottom plate allows high strength for stripping and erecting. Reinforcement required to develop SWL.



When used in shear, the load should be perpendicular to the face of the anchor.

TON	SYS CODE	ITEM CODE	ANCHOR DEPTH (L)	BODY WIDTH (W)	BODY THICK. (T)	BASE WIDTH (A)	BASE LENGTH (C)	MIN EDGE DIST.	SWL TENSION (LBS)	SWL SHEAR (LBS)	SWL TENSION REINFORCED (LBS)	SWL SHEAR REINFORCED (LBS)	UML (LBS)
2	2.5	FPA02023	2-1/4"	1-1/4"	3/8"	1-1/4"	3-3/4"	4-1/2"	2043	2043	4000	4000	16000
4	5	FPA04030	3"	1-1/2"	5/8"	1-1/2"	3"	5-3/4"	3422	3422	8000	8000	32000
4	5	FPA04035	3-1/2"	1-1/2"	5/8"	1-1/2"	3"	6-1/2"	4095	4095	8000	8000	32000
4	5	FPA04044	4-3/8"	1-1/2"	5/8"	1-1/2"	3-7/8"	7-3/4"	5178	5178	8000	8000	32000
4	5	FPA04063	6-1/8"	1-1/2"	5/8"	1-1/2"	3-7/8"	10-1/2"	8000	8000	8000	8000	32000
8	10	FPA08061	6-1/4"	2-1/2"	3/4"	2-1/2"	5"	11-1/2"	7726	7726	12000	12000	64000
8	10	FPA08071-1	7-1/8"	2-1/2"	3/4"	2-1/2"	4"	12"	9054	9054	16000	16000	64000
8	10	FPA08073	7"	3"	3/4"	3"	4"	12"	9054	9054	16000	16000	64000
8	10	FPA08093	9"	3"	3/4"	3"	4"	15-1/2"	12920	12920	16000	16000	64000

Safe working loads based on approximate 4:1 Safety Factor in 3,500 psi normal weight concrete.

UML= Ultimate Mechanical Load

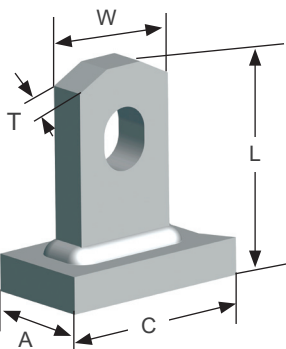

Reinforced Allowable Tension Capacities require the use of additional rebars positioned as shown over the base plate of the anchor.

- For 2 Ton anchors, use 2 x #4 rebars x 12" long each direction (in 3500 psi concrete).
- For 4 and 8 Ton anchors (FPA08061), use 2 x #4 rebars x 18" long each direction (in 3500 psi concrete).
- For 8 Ton anchors (FPA08071-1 and longer), use 2 x #4 rebars x 21" long each direction (in 3500 psi concrete).

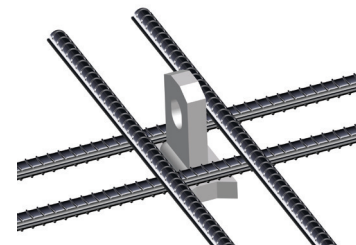

TT Anchor System

Designed for lifting precast double tees, available in 7.5T and 10T. Available in three styles to accommodate different strand configurations.

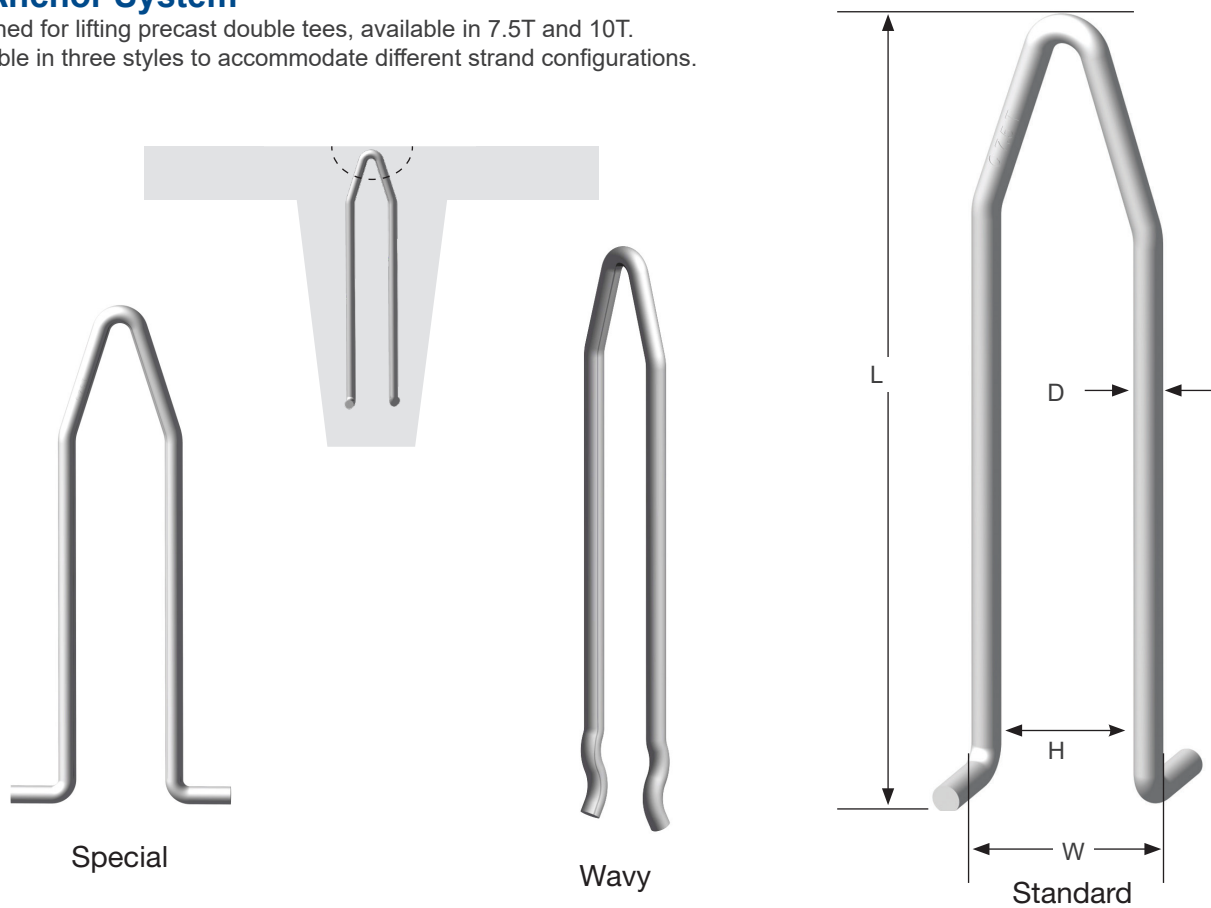

TON	SYS CODE	ITEM CODE	LENGTH (L)	Standard	Special	Wavy	INSIDE WIDTH (H)	DIAMETER (D)	SWL TENSION (LBS)	UML TENSION (LBS)
				OUTSIDE WIDTH (W)	OUTSIDE WIDTH (W)	OUTSIDE WIDTH (W)				
7.5	10	TT 7.5T	18"	4-3/8"	7-3/4"	N/A	3-1/8"	16 MM	15000	60000
10*	10	TT 10T	22-7/8"	3-7/8"	7-7/8"	3-7/8"	2-5/16"	20 MM	20000	80000

UML= Ultimate Mechanical Load in tension

Safe working loads based on approximate 4:1 Safety Factor in 3,500 psi normal weight concrete.

*CONAC FRC11B (11 Ton Ring Clutch) must be used for 20,000 SWL.

TT Recess Former

Designed for use with CONAC Double Tee and Safe Lift anchors.

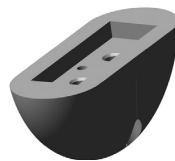

Safe Lift Anchor

Designed for face-lifting solid panels or insulated panels with sufficient thickness of back wythe.

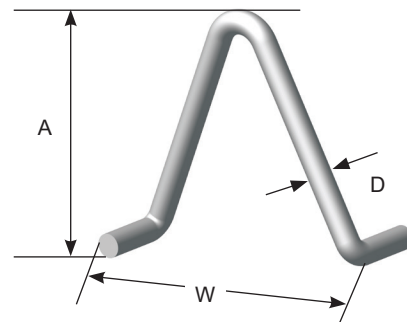

ITEM CODE	ANCHOR DEPTH (A)	ANCHOR WIDTH (W)	BODY DIAMETER (D)	PANEL DEPTH	SWL TENSION (LBS)	SWL SHEAR (LBS)
SF-ANCHOR 6T	7-3/4"	6"	.70"	8"	10000	13000

Safe working loads based on approximate 4:1 Safety Factor in 4,000 psi normal weight concrete

Flat Steel System



Rubber Recess Former

Reusable recess member. When attached to holding plate, allows positioning and handling of anchor.

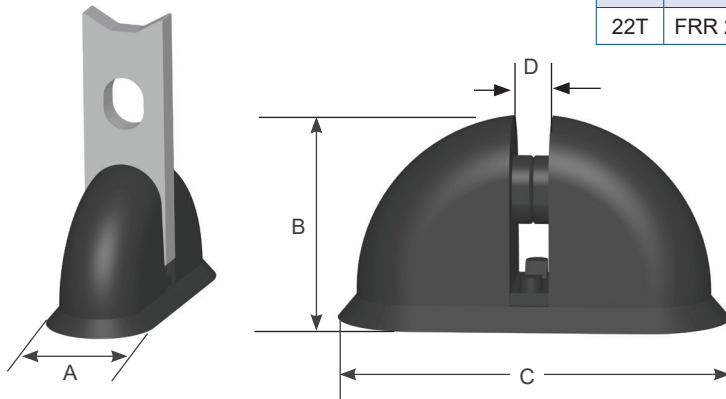

TON	ITEM CODE	A	B	C	D	SYSTEM CODE
2T	FPRF02	1-3/4"	2"	3-5/8"	3/8"	2.5T
4T	FPRF04	2-1/8"	2-5/16"	4-1/2"	5/8"	5.0T
8T	FPRF08	2-3/4"	3-1/2"	6-1/2"	3/4"	10.0T
22T	FRR 22	4-1/4"	4-5/8"	9-3/8"	1-1/4"	22.0T

Plastic Recess Former

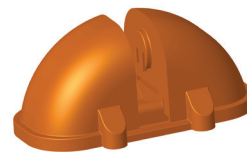
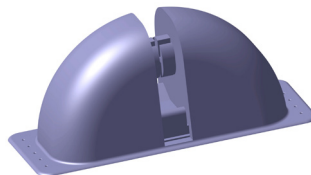
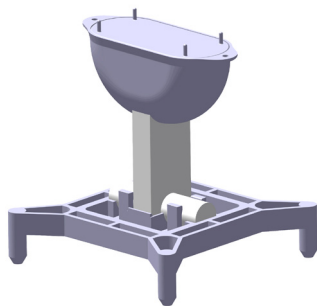

TON	ITEM CODE	A	B	C	D	SYSTEM CODE
4T	FPRF04-EA	1-7/8"	2-1/4"	4-15/16"	5/8"	5.0T
8T	FPRF08-EA	3-1/8"	3-1/4"	7-7/8"	3/4"	10.0T
4T	FTARRF	PLASTIC FORMER FOR T-BAR ANCHOR				
4T	FTA BASE	PLASTIC BASE FOR T-BAR ANCHOR				

Magnetic Rubber Recess Former

To attach flat steel anchors to steel forms.

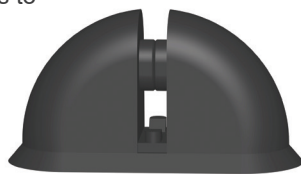

TON	ITEM CODE	A	B	C	D	SYSTEM CODE
2T	FRR02M	1-3/4"	2"	3-5/8"	3/8"	2.5T
4T	FRR04M	2-1/8"	2-5/16"	4-1/2"	5/8"	5.0T
8T	FRR08M	2-3/4"	3-1/2"	6-1/2"	3/4"	10.0T

Other sizes available by request.

Foam Strips

Prevents concrete entering the void when using steel recess former.

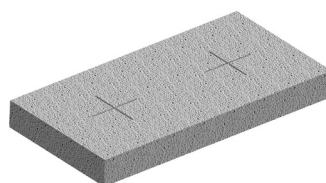

TON	ITEM CODE	A	SYSTEM CODE
2T	FEA02RF	1/4" X 1-3/4" X 4"	2.5T
4T	FEA04RF	1/4" X 1-3/4" X 4"	5.0T
8T	FEA08RF	5/8" X 3" X 6"	10.0T

Holding Plate

May be attached to form by nail holes, screw holes, or welding. Used to hold recess former.

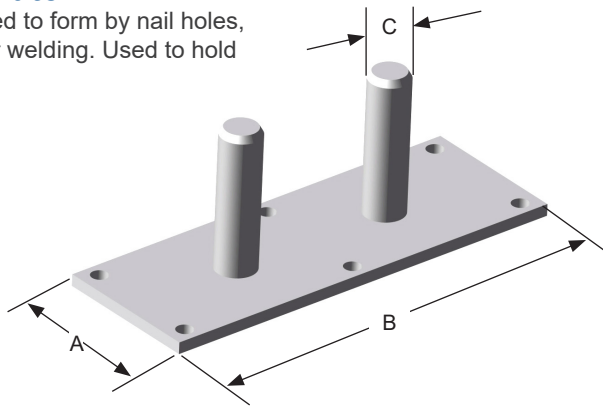

TON	ITEM CODE	A	B	C	SYSEM CODE
2T	FHP02	5/8"	2-3/4"	10mm	2.5T
4T	FHP04	1-1/4"	3-3/8"	10mm	5.0T
8T	FHP08	1-3/4"	4-7/8"	12mm	10.0T
22T	FHP22	2-1/2"	7"	16mm	22.0T

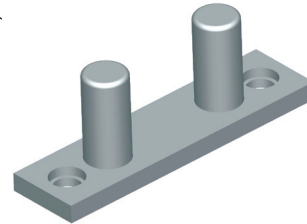

Wing Nut & Bolt Assembly

Used to attach recess former to form.

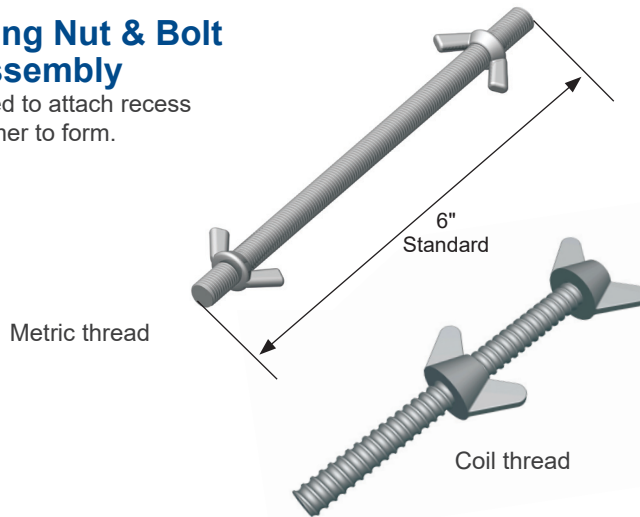

TON	ITEM CODE	STANDARD ROD LENGTH	THREAD DIAMETER & TYPE	SYSTEM CODE
2T	FWN02	6"	M8	2.5T
4T	FWN04	6"	M8	5.0T
8T	FWN08	6"	M12	10.0T
22T	FWNC 1/2"	5-1/2"	1/2" COIL	22.0T
	FWNC 1/2"	5-1/2"	1/2" COIL	5.0T
	FWNC 3/8"	6"	3/8" COIL	5.0T

Shear Bar

Used with flat steel erection anchor to increase shear capacity.

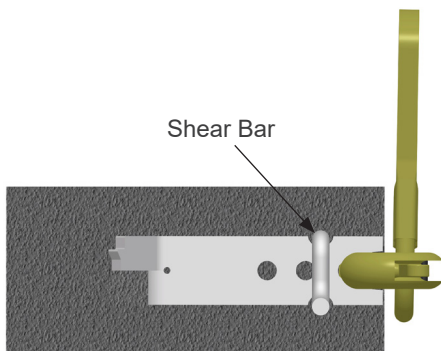

TON	ITEM CODE	SHEAR BAR DIAMETER	MIN. PANEL THICKNESS	HIGH (H)	LENGTH (L)	SYSTEM CODE
2T	FSB02	1/2"	4"	2-1/2"	13-7/8"	2.5T
4T	FSB04	1/2"	5-1/2"	3-5/16"	13-7/8"	5.0T
8T	FSB08	1/2"	7-1/2"	4-15/16"	13-7/8"	10.0T

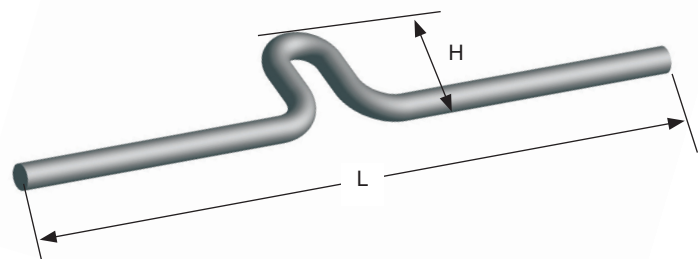

Flat Steel System



Ring Clutch With Bail

Designed to be used specifically for flat steel lifting.
 Handle allows for safe locking of clutch into lifting position.
 Standard finish plated.

TON	ITEM CODE	A	B	C	D	E	F	G	SYS. CODE
2-3T	FRC02 B	3-5/8"	2-1/8"	10-1/2"	3"	7"	2-3/4"	1-1/4"	2.5T
4-6T	FRC04 B	4-1/2"	2-5/8"	12-7/8"	4"	8-1/2"	3-1/2"	1-1/2"	5T
8-10T	FRC08 B	5-1/2"	3"	17"	5-7/8"	10-3/8"	4-1/2"	1-3/4"	10T
11T	FRC11 B	5-1/2"	3"	17"	5-7/8"	10-3/8"	4-1/2"	1-3/4"	10T
12T	FRC12 B	5-1/2"	3"	17"	5-7/8"	10-3/8"	4-1/2"	1-3/4"	10T
22T	FRC22 B	8-3/8"	4-1/2"	24"	8"	15"	6-3/4"	2-5/8"	22T

Safe working loads based on 5:1 Safety Factor.

TON	ITEM CODE	H
2-3T	FRC02B	0.559"
4-6T	FRC04B	0.728"
8-10T	FRC08B	0.885"
11T	FRC11B	0.885"
12T	FRC12B	0.885"
22T	FRC22B	1.385"

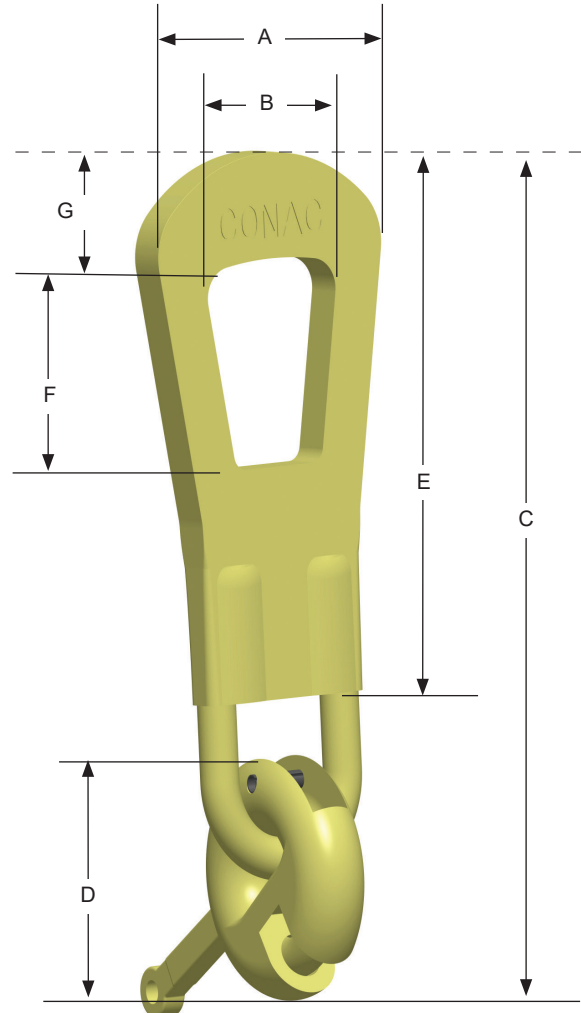

3. Operating Instructions

The CONAC Ring Clutch can be used for parallel/transversal shear pulls (Figure 1 & 2) and straight tension pulls (figure 2).

INCORRECT
 Bail should never contact edge of concrete to avoid bending the bail.

CORRECT
 Load line should be in line with the center of the bail, lifting from the top of the bail only.

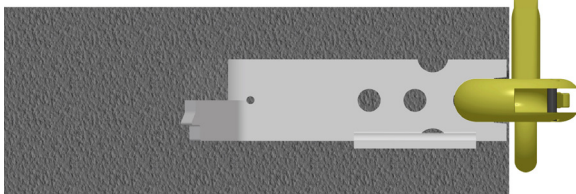

Figure 1

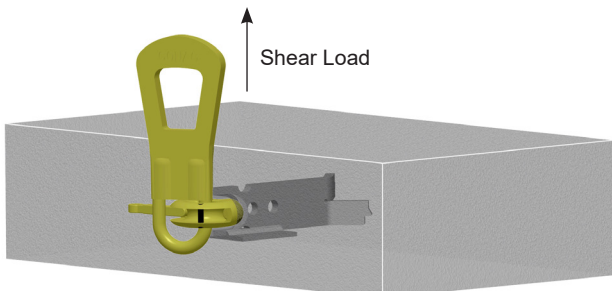

Figure 2

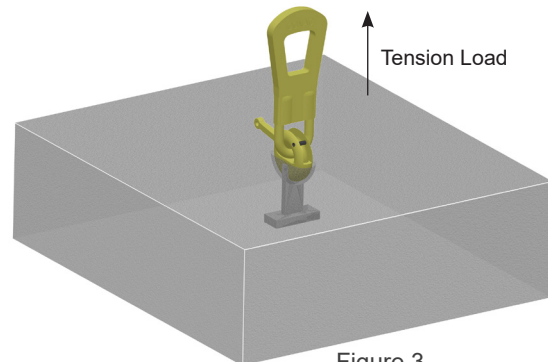

Figure 3

1. General

The CONAC Ring Clutch is a load lifting device. It engages the head of a Flat Steel anchor inside of the recess created by the CONAC Recess Former. The bail is made from robust, hardened and tempered cast steel. The CONAC Ring Clutch meets the requirements of the "Safety regulations for lifting precast concrete units". Important references include but are not limited to: OSHA Part 1926 and ANSI 10.9.

2. Identification

The identification meets the "Safety regulations for lifting precast concrete units" as follows:

Manufacturer	CONAC
Type	Ring Clutch
Size	e.g. 4T
Manufacture Year	e.g. 20
Batch Number	e.g.1234

3. Care, Inspection and Maintenance of Ring Clutches (For Both Steel Bail and Cable)

CONAC Flat Steel System Ring Clutches may become worn after extended use or may be damaged through misuse, overloading, or a number of other factors, any one of which may affect the Safe Working Load of the Ring Clutch.

Users must establish a system of periodic inspections which should include the following:

1. Inspect for general condition and wear.
2. Assure that the bail is free to rotate in all directions.
3. If the bail is bent or twisted, the clutch must be destroyed.
4. Check the curved bolt for wear, cracking or bending.
5. Check the clutch body for wear, cracking or deformation.
6. If it appears that the Ring Clutch has been heated in any way, the clutch must be destroyed.
7. Check the engagement slot, if the gap is larger than dimension H, the clutch must be destroyed.

Destroy any unit that is worn, damaged, bent or twisted by cutting off the bail. No repair or welding is permitted.

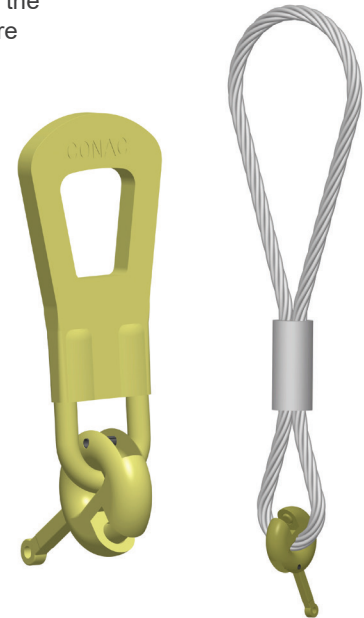

Flat Steel System



Ring Clutch W/Cable

Designed to be used specifically for flat steel lifting. Cable is more flexible than bail allowing some latitude in the direction of lift. Handle allows for a more safe locking of clutch into lifting position.

TON	ITEM CODE	A	B	D	E	SYSTEM CODE
2-3T	FRC02	23-1/2"	14 mm	3"	12"	2.5T
4-6T	FRC04	25-1/2"	18 mm	4"	12"	5.0T
8-10T	FRC08	31"	22 mm	5-7/8"	12"	10.0T
11T	FRC11	31"	22 mm	5-7/8"	12"	10.0T

Safe working loads based on 5:1 Safety Factor.

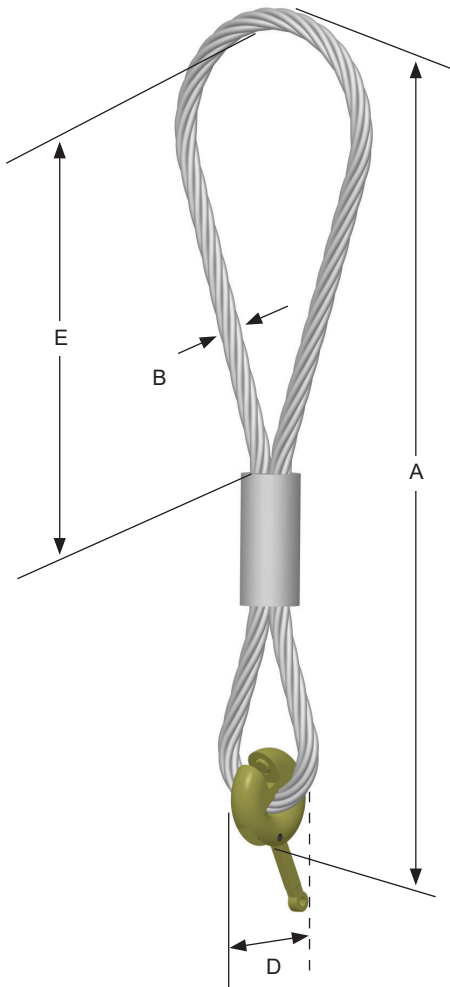

CARE, INSPECTION AND MAINTENANCE OF RING CLUTCHES (FOR BOTH STEEL BAIL AND CABLE BAIL)

CONAC Flat Steel System Ring Clutches may become worn after extended use or may be damaged through misuse, overloading, or a number of other factors, any one of which may affect the Safe Working Load of the Ring Clutch.

Responsible users will establish a system of periodic inspections which should include the following:

1. Inspect for general condition and wear.
2. Assure that the bail is free to rotate in all directions.
3. If the bail is bent or twisted, the clutch must be destroyed.
4. Check the curved bolt for wear, cracking or bending.
5. Check the clutch body for wear, cracking or deformation.
6. If it appears that the Ring Clutch has been heated in any way, the clutch must be destroyed.
7. Check the engagement slot, if the gap is larger than dimension H, the clutch must be destroyed.

TON	ITEM CODE	H (MAX)
2-3T	FRC02	0.619"
4-6T	FRC04	0.787"
8-10T	FRC08	0.944"
11T	FRC11	0.944"
12T	FRC12B	0.944"

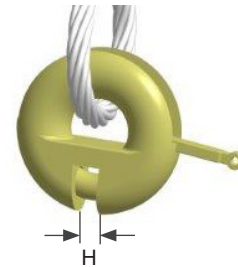

ADDITIONAL INSPECTION OF CABLE BAIL

1. Inspect cable for general condition and wear.
2. Check cable for nicks, kinks, crushing or bends.
3. Check for frayed or loose outer strands.
4. Check for cable swelling.

If the cable is damaged, the Ring Clutch must be destroyed as above. Destroy any unit that is worn, damaged, bent or twisted by cutting off the bail. No repair or welding is permitted.

